

Emergency Backup Power Supply

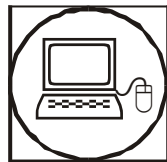

For Use With Computer Loads Only



Power Surge/Noise Protection

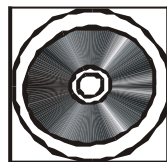

Intelligent Auto-Shutdown Software



Internet Line Protection



Cost Efficiency

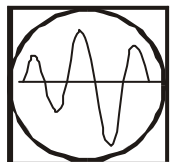

AVR Protection

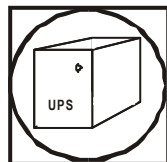

Compact & Reliable Design

USER'S MANUAL

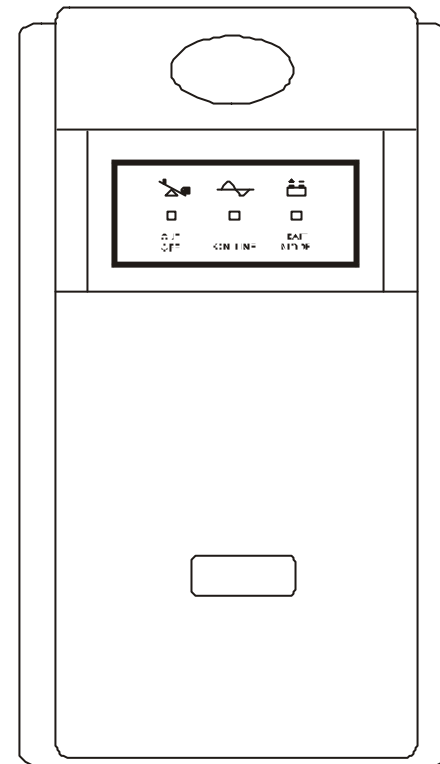

1st Edition

Uninterruptible Power System

IP-021-a3-01

IMPORTANT SAFETY INSTRUCTIONS

Thank you for selecting this uninterruptible power system (UPS). It provides you with better protection for connected equipment.

Please read this manual !

This manual provides safety, installation and operating instructions that will help you derive the fullest performance and service life that the UPS has to offer.

Please save this manual !

It includes important instructions for the safe use of this UPS and for obtaining factory service should the proper operation of the UPS come into question.

Please save or recycle the packaging materials !

The UPS's shipping materials were designed with great care to provide protection from transportation related damage. These materials are invaluable if you ever have to return the UPS for service. Damage sustained during transit is not covered under the warranty.

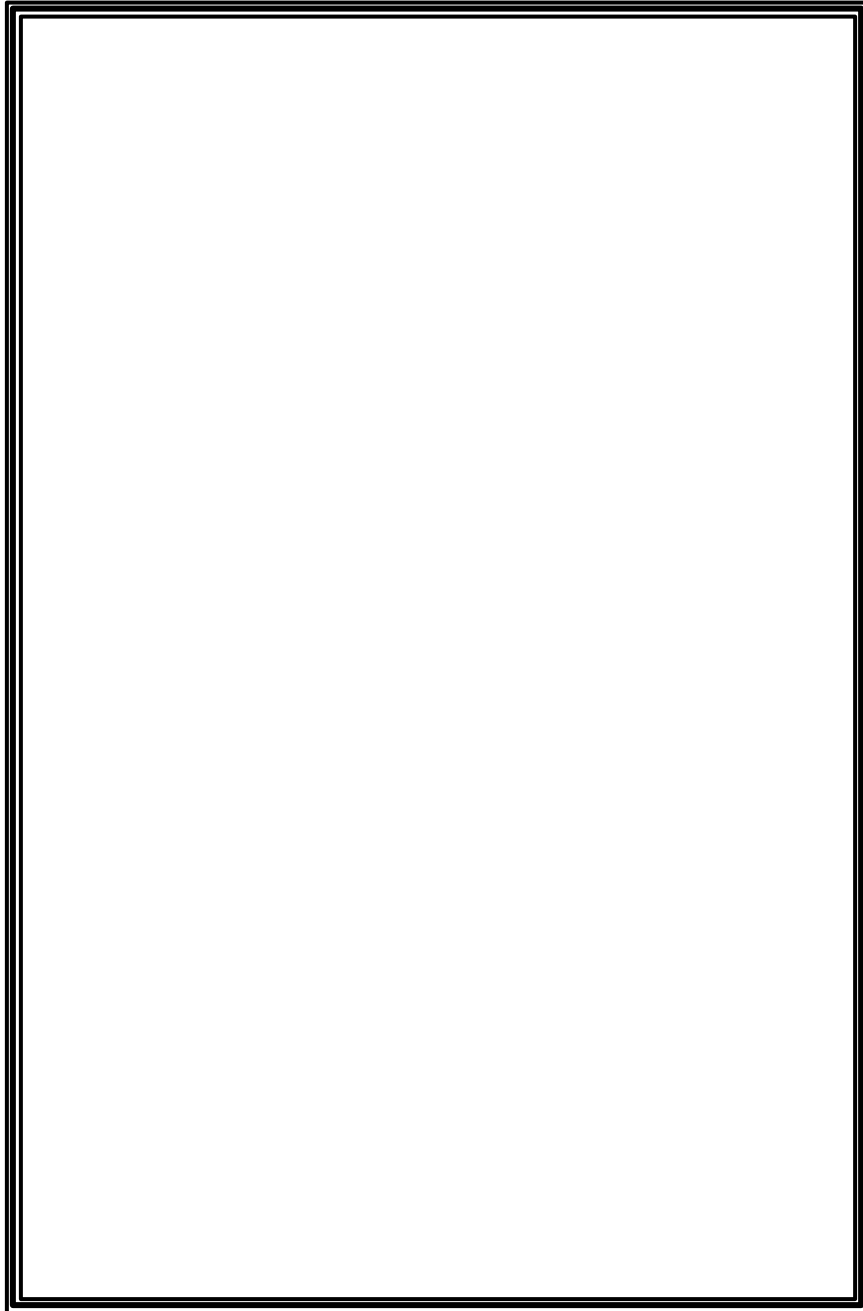

NOTES

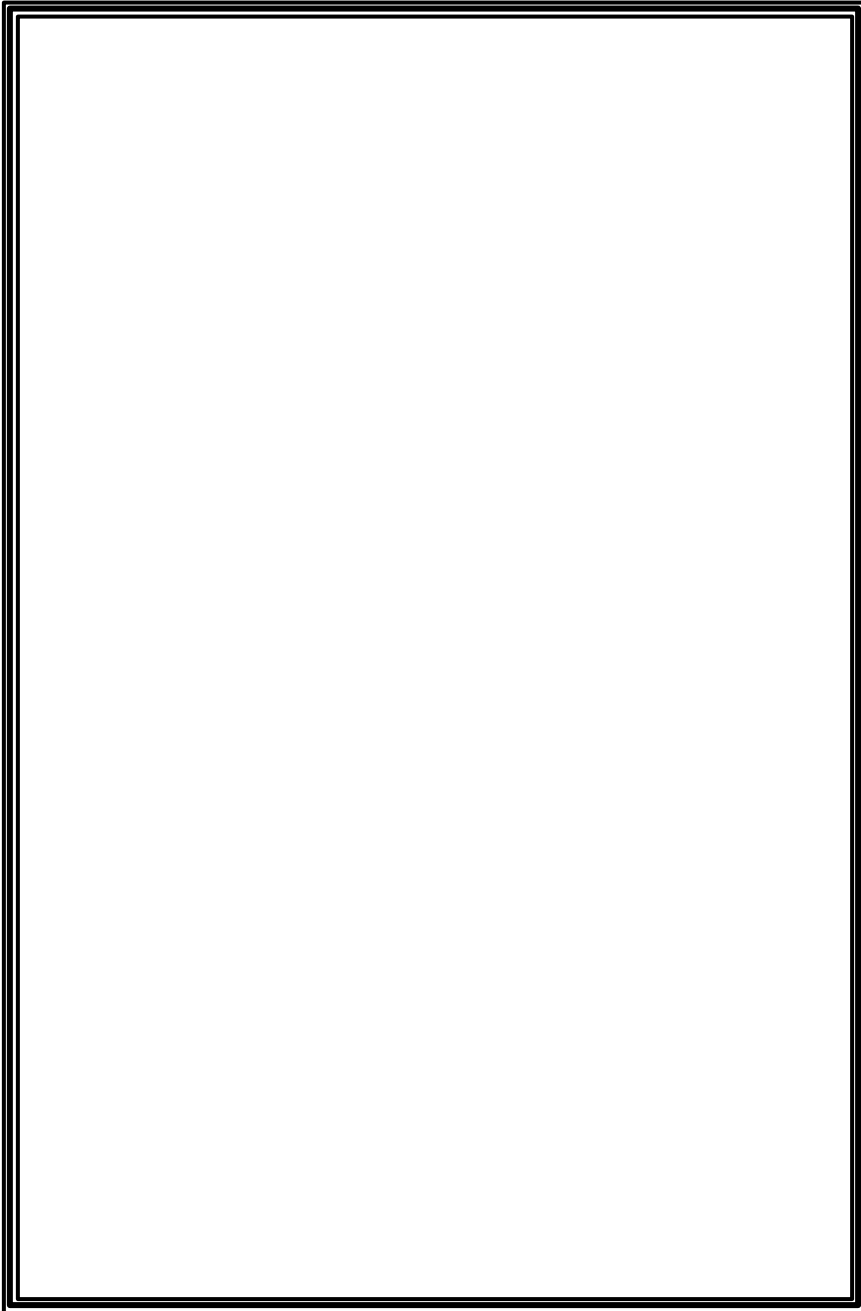

CAUTION

- The UPS contains voltage that are potentially hazardous. All repairs should be performed by qualified service personal.
- The UPS has its own internal energy source (battery). The output receptacles may be alive even when the UPS is not connected to an AC supply.
- The UPS is suitable for computers and electronic equipment with substantially rectifier or capacitive loads, not suitable for electronic equipment with significant inductive loads, such as motors & fluorescent lamps.
- Be sure to operate within the power rating of the UPS. Below 1/2 or 1/3 of rated power is recommended for longer backup time & longer battery life.
- Do not place the UPS near excessive humidity, under sunshine, or close to heat-emitting sources.
- If the UPS is out of order, please detach power cord and consult your dealer right away. Do not remove cover if there is no serviceable part inside.
- The unit should be supplied by grounded source. Do not operate the unit without ground source.
- The socket-outlet should be installed near the equipment and be easily accessible.
- Do not plug the UPS power cord into itself. That will result in a safety hazard.
- Installation should be performed by a qualified technician or electrician in accordance with local electrical codes.

SPECIFICATIONS

Capacity	VA	400VA	500VA	600VA	800VA	1000VA
Input	Voltage	100VAC, 110VAC, 120VAC, 220VAC, 230VAC or 240VAC ±25%				
	Frequency	50Hz or 60Hz ±5%				
Output	Voltage (Batt. Mode)	100VAC, 110VAC, 120VAC, 220VAC, 230VAC or 240VAC ±10%,				
	Frequency	50Hz or 60Hz ±1Hz				
	Waveform	Modified sine wave				
	Transfer Time	Less than 4ms (typical)				
Battery	Battery Type	Sealed, maintenance-free lead acid batteries with 3-6 years typical lifetime				
	Recharge Time	5 hours to 90% of full capacity				
Indicator	LED	LED indicator for line on, battery back-up, UPS cut-off				
Alarm	Battery Back-up	Sounding every 3 seconds				
	Battery Low	Sounding every 1 second				
	Overload	Continue beeping sound				
Protection	Overload	Fuse & current limited				
	Short Circuit	Fuse & current limited & cut-off				
	Batt. Low Cut-off	No battery drain after cut-off				
Physical	Dimension, D*W*H	270*94*170 mm		385*94*170 mm		
Environment	Operating Temperature	32 -104 at full load, 0~90% relative humidity (non-condensing)				
	Noise Level	Less than 40db (at 1 meter)				
Interface	Contact Closure	DB9 connector for connecting with Rups-2000 software				
	Software	Rups-2000 (Option)				

SYSTEM CONCEPT

The purpose to present this chapter is to give you more precise conception about how UPS works..

1. Block Diagram

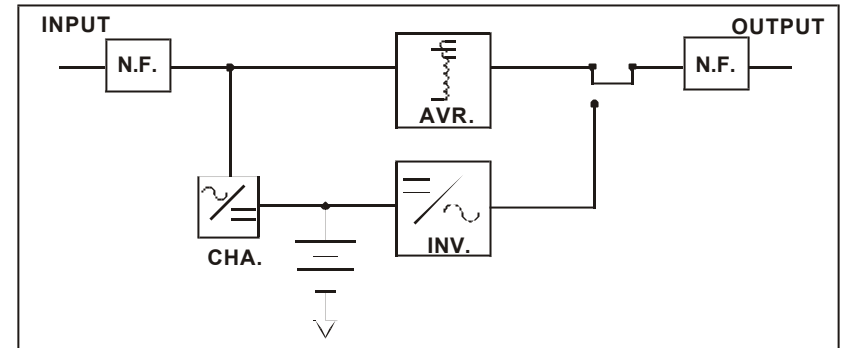

Fig. 1 shows how UPS works.

2. Normal Operation

There are two main loops when AC Utility normal the AC output loop and the battery charging loop. The AC output gets power from AC utility input and pass through AVR to support power to load. In the same time, the AC utility input is converted by AC/DC CHA and support charging power to charge batteries.

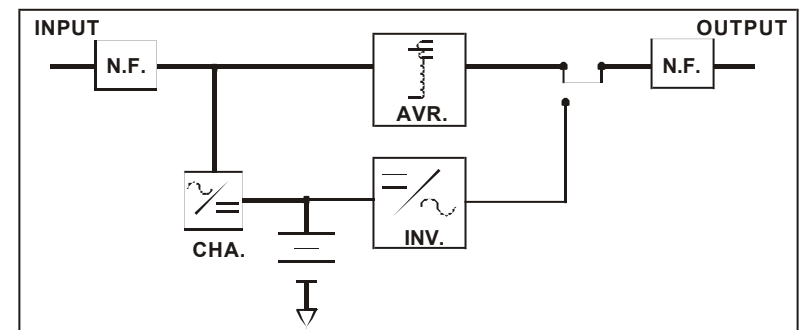

Fig. 2 shows how the UPS works when AC Utility normal.

COMPUTER INTERFACE

The computer interface (DB9 port) on the back of the UPS may be connected to a host computer. This port allows the computer to monitor the status of the UPS and control the operation of the UPS.

Pin out information:

PIN#	Description	I/O
PIN1	Battery low, normally open, active close	Output
PIN2	N.C.	
PIN3	Common Ground	
PIN4	Remote shut down, keep this pin high (+5~+12V) for 3S will turn off the UPS	Input
PIN5	N.C.	
PIN6	N.C.	
PIN7	Must keep in high state	Input
PIN8	Line fail, normally open, active close	Output
PIN9	N.C.	

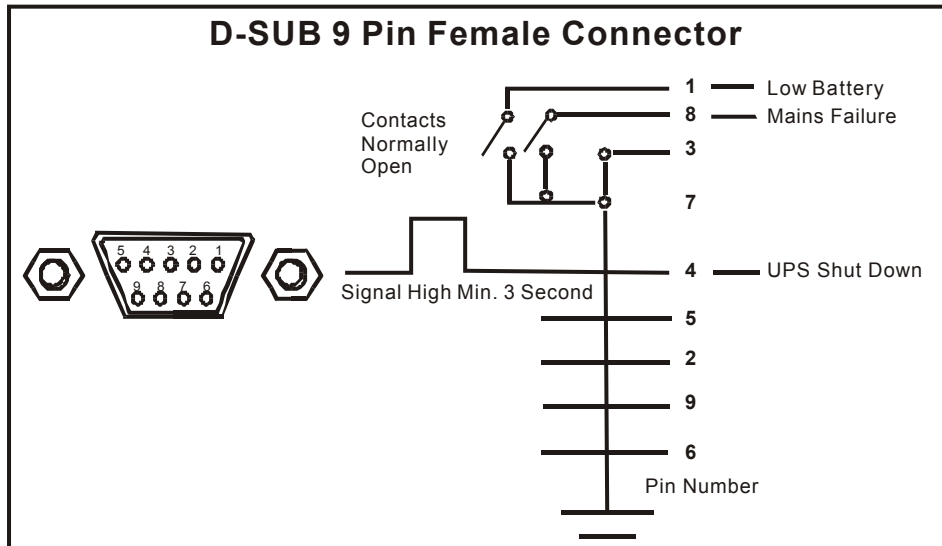

OVERVIEW

Front Panel

1. **Master Power Switch:** Turn on/off the UPS.
2. **LINE-ON:** AC Normal .
3. **BACK-UP:** Battery in back-up
4. **UPS Cut-off:** Overload or Cut-off

Rear Panel

1. **Input:** IEC type connector to connect the power cable.
2. **AC Fuse:** Protection against short-circuits electronic fuse.
3. **Data line protection:** Filtering of electrical noise on data transmission lines.
4. **Communication port:** Basic communications.
5. **AC/Battery outputs:** Output protected for critical loads that require additional electrical power
6. **UPS function setup:** No load auto-shut down, Dc-start On and Buzzer Alarm auto-reset.

Picture:

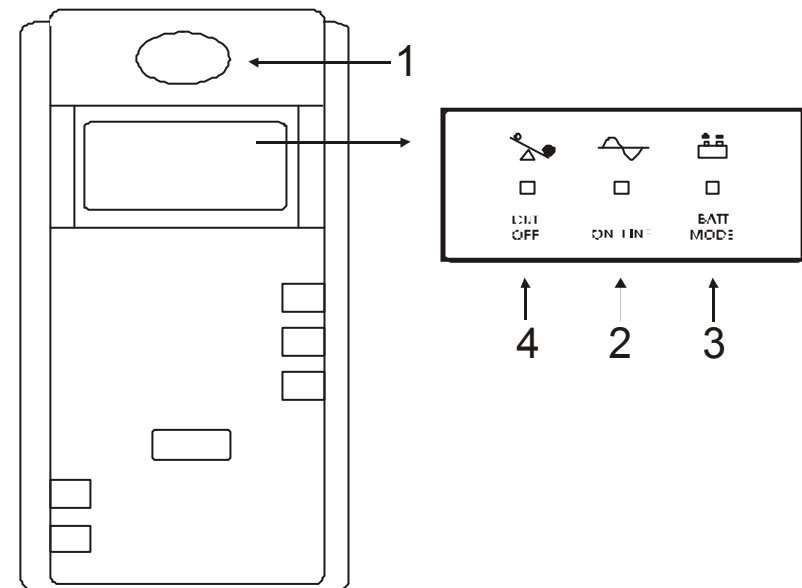

Front Panel

CONTENTS

	PAGE
1. CAUTION.....	1
2. INTRODUCTION	
SYSTEM DESCRIPTION.....	2
FEATURES.....	2
3. SYSTEM CONCEPT	
BLOCK DIAGRAM.....	3
NORMAL OPERATION.....	3
AC UTILITY FAILURE.....	4
4. OVERVIEW	
FRONT PANEL.....	5
REAL PANEL.....	5
PICTURE.....	5
5. INSTALLATION AND OPERATION.....	7
6. COMPUTER INTERFACE.....	8
7. BATTERY FACTS.....	9
8. SPECIFICATIONS.....	10
9. TROUBLE SHOOTING.....	11
10. NOTES.....	12

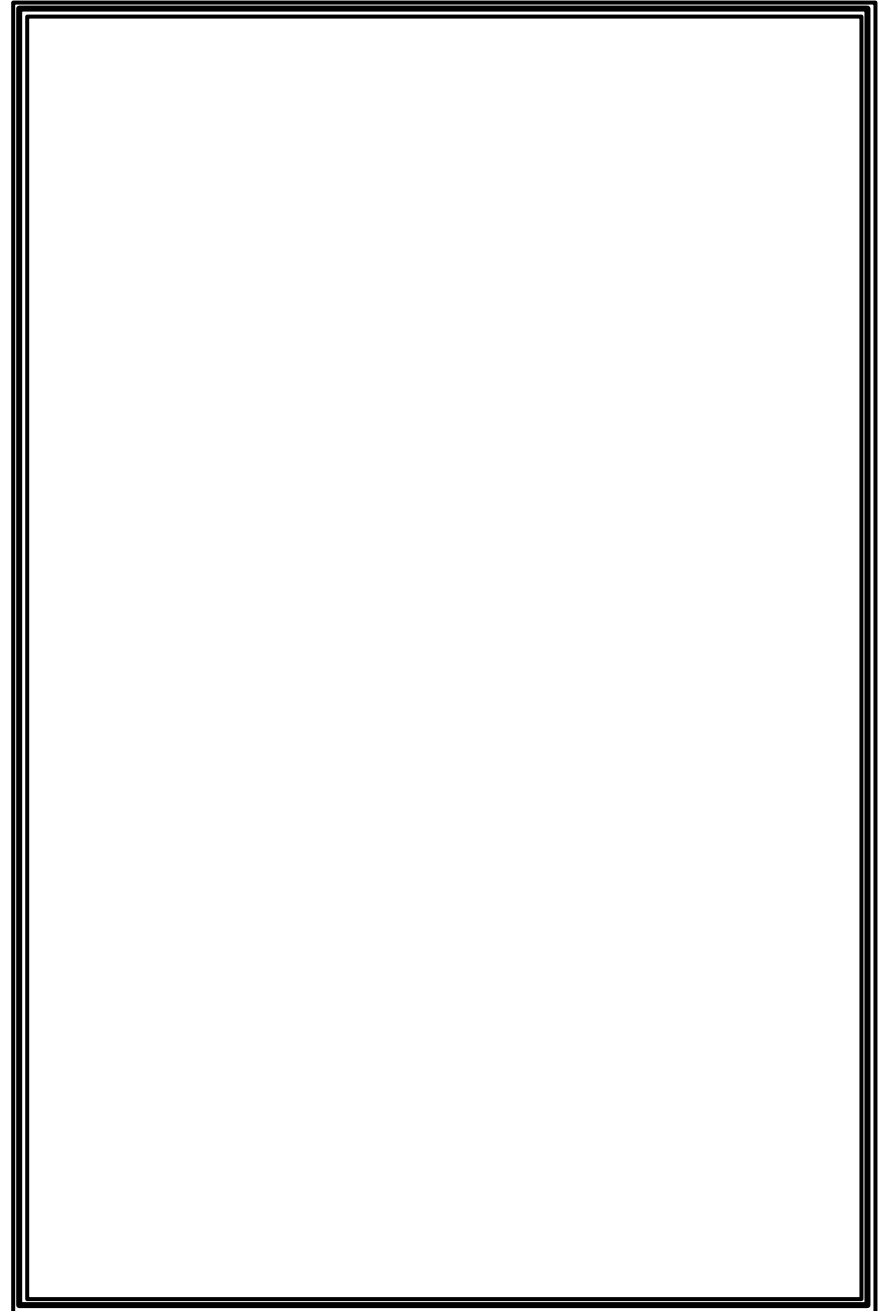

INTRODUCTION

System Description

The product is line interactive UPS with the newest technology and powerful function. The Line Interactive UPS is with AVR function allows input voltage range from 75% to 125%, including on line voltage boost-up & buck down.

An ideal protection equipment for critical connected loads.

In addition, This UPS provides advanced single telephone line or modem surge suppression through the modular connectors on the back panel.

The Line Interactive UPS and RUPS2000 monitoring software (Optional kits) makes our computer operate intelligent and provides you with the ability of perfect protection of your critical devices.

Features

- Line interactive design.
- Easy LED display.
- Provide boost and buck AVR to stabilize input voltage.
- Provides lightning, surge, overload, and short-circuit protection.
- Built-in CCCV battery charger and battery over drain protection.
- Auto restart when AC recovery.
- Cold start function (Dip power on).
- Tel / Modem / Fax / Internet surge suppression.
- Option Bundle software : Automatically save your valuable files before auto shutdown.

TROUBLE SHOOTING

If the UPS failed to operate properly, please review the following checks firstly. If the problem remain, please consult sales agent for service.

- Is the Master power switched on?
- Is the UPS plugged into a correctly working outlet?
- Is the line voltage within the rating specified?
- Is the fuse on the rear panel blown?
- Is the UPS over loaded?
- Is battery not fully charged? Dead battery? Charger failure?

Please provide the following information when call for service.

1. Model number, serial number.
2. Date of the problem occurred, date of purchase.
3. Full description of the problem including load, LED, and alarm status, installation condition, working environment, etc.

Trouble-Shooting Chart		
Problem	Possible Cause	Caution To Take
No light, and no alarm (UPS not on)	Front panel switch in off position.	Turn on switch.
	Rear panel fuse burnout.	Replace fuse restart UPS.
	Power cord lose	Check input power.
No "Line-on LED" light, and alarm beeps every few seconds.	Power cord lose	Check input power.
	AC Fuse burnout.	Replace fuse, if problem remains, call for service.
Backup time is less than the rating.	Battery is not fully charger failure.	Recharge the battery for at least 6 hours, re-test the backup time. If problem remains, call for service.

BATTERY FACTS

3. AC Utility Failure

If AC utility fails, the UPS quickly detects the problem and activates the inverter. The DC/AC inverter changes DC power from the batteries into AC and provides continuous uninterruptible power to load.

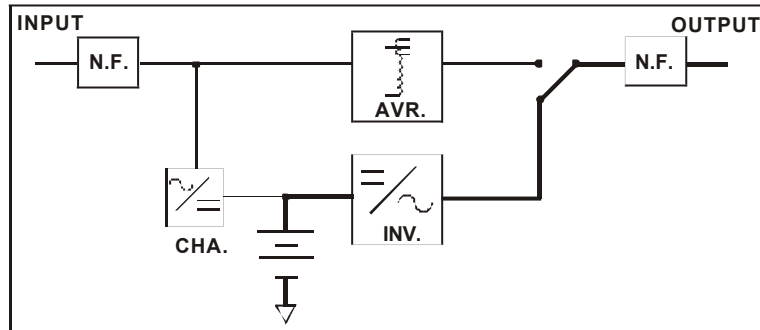

Fig. 3 shows how the UPS works when AC Utility Failure

The battery is the only periodically serviceable parts in the UPS. An expected life is approx. 3-5 years. However, frequent long discharges or ambient temperatures above 80°F will shorten battery life. Therefore, it is recommended to replace the batteries every 3 years after initiating the unit.

Recharge batteries every 3 months is necessary if it is not in use because it may cause batteries over-drain.

WARNING

Only a qualified technician should replace the battery. Batteries have high short-circuit current capacity; mistakes in connecting or disconnecting can cause connections to arc or weld and could cause severe burns.

STORAGE

The UPS should only be stored if the battery is fully charged. Avoid storage temperatures above 80°F as battery life is significantly shortened. Every 90 days remove the unit from storage and plug it in for 24 hours to recharge the batteries. Batteries may be damaged if left in storage and not recharge every 90 days.

IMPORTANT NOTICE

Please use same type and same rating of batteries for replacement.
Do not replace it with the battery that exceeds specified rating.

INSTALLATION AND OPERATION

Rear Panel:

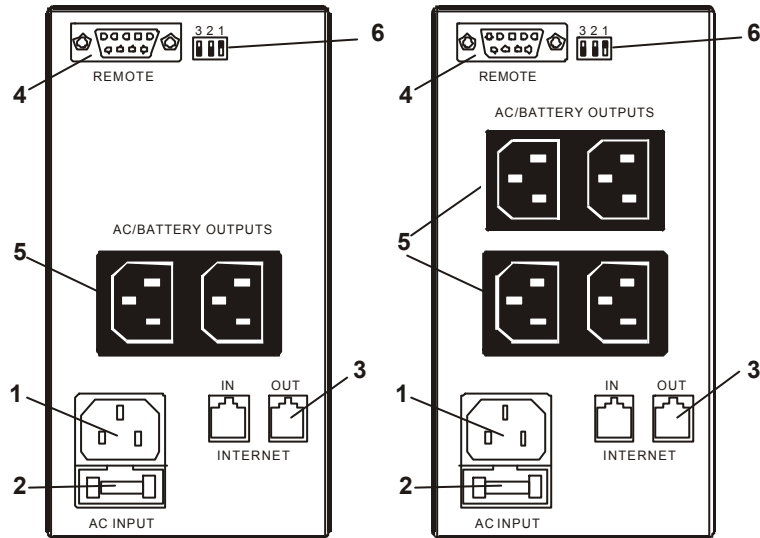

IEC-320

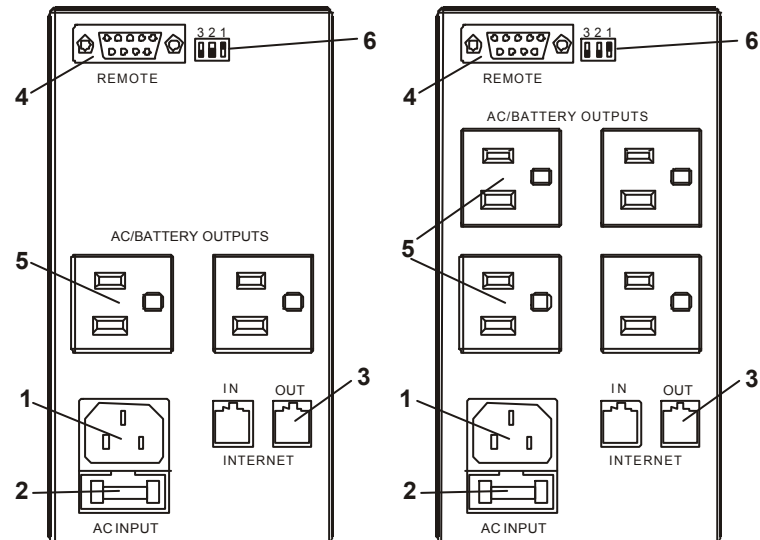

NEMA5-15R

Upon receipt of the UPS, inspect the shipping carton for damage. If there is any obvious damage, immediately report it to the selling dealer or the delivering carrier. If there is no damage to the shipping carton, unpack the unit and inspect the unit for damage.

The UPS is designed for installation in a protected environment within a temperature range from 32 F to 104 F and relative humidity of 0-90% without condensation. Do not block inlets and outlets. Install the system in a location free from excessive dust and chemical fumes.

Check the identification label to verify the UPS voltage and power rating match the available line voltage and load requirements.

Installation:

1. Check if the main switch on the UPS front panel is in the off position and insure that the voltage of the AC utility source corresponds to the nameplate on the UPS rear panel.
2. Connect the power cord to a verified grounded 3-wire receptacle.
3. Turn on the power switch of UPS, the green LED will be lit indicating AC utility voltage is present.
4. Charge the batteries for ten (10) hours before use. You may use the UPS immediately without recharging, but the backup time maybe less than the rating.
5. Connect your computer to the output receptacles of the UPS.
6. To test backup function, you may disconnect the power cord of the UPS from wall outlet. The Yellow LED will light on, and alarm will beep every 3 seconds.
7. When battery approaches low level, alarm will beep every second until auto shut down.
8. The 4 conditions UPS will automatically shut down:
 - a. Battery low
 - b. Short circuit
 - c. Overload
 - d. UPS fault